

Type	A	B	C	D
FS-455 T	660	526	132	285

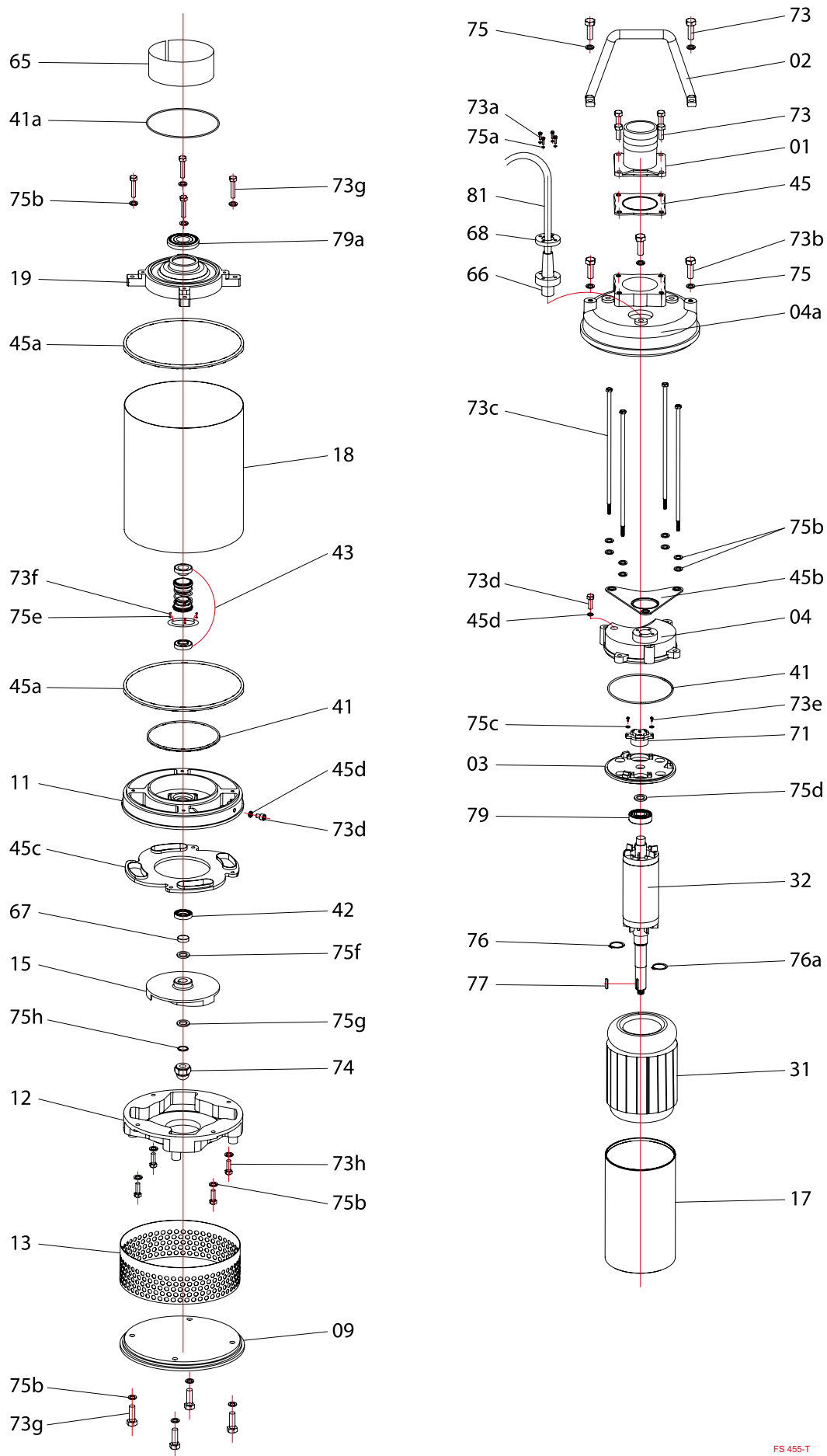

Index	Code NO	Description	Q'ty	Size	Material
01	01360842	Discharge head	1	4"	FC-20
02	02303-1	Handle	1		SC
03	0336FS-0550	Switch plate	1		FC-20
04	0436FS-0550	Motor cover	1		FC-20
04a	0436FS-0550F	Upper cover	1		FC-20
09	0935FS-0550	Base plate	1		FCD-45
11	1136FS-0550	Seal braket	1		FC-20
12	1236FS-0550C	Inlet plate	1	4"	FC-20
13	13431009010	Strainer	1	10MM*90*834	SUS-304
15	1541FS-0550165	Impeller	1	165*5*20	High Chrome Steel
17	1743160275	Motor frame	1	160*275H	SUS-304
18	1843FS-0550	Outer case	1	259*302H	SUS-304
19	1936FS0550	Bearing bracket	1		FC-20
31	313440514F6	Stator	1	160*82*140L 415V	
32	323FS-0550	Shaft/Rotor without Bearing	1	160*82*140L	
41	411031-07	O'ring	2	3.1MM*155	N-70
41a	411026-02	O'ring	1	2.62MM*158.4	N-70
42	4214325-01	Oil seal	1	25MM-40*8	SUS-304
43	432225-01	Mech.seal	1	Double 25 SIC/SIC VS CM/CB	
45	455FS-055010	Gasket	1		N-70
45a	456FS-055010	Gasket	2		N-70
45b	451FS-055010	Gasket	1		N-70
45c	454FS-055010	Volute liner	1		N-70
45d	459010	Gasket	2		N-70
65	6531160	Shim	1	60MM	
66	66715125	Cable gland	1		
67	674325-02	Shaft sleeve	1	25MM*20*2T	SUS-304
68	68432	Gland Holder	1		SUS-304
71	7128-05	Thermal protector	1	HKXL00	
73	73431100301	Screw	6	Flat hex. M10*30	SUS-304
73a	73432060161	Screw	4	Socket hex. M6*16	SUS-304
73b	73431100401	Screw	3	Flat hex.M10*40	SUS-304
73c	73436083051	Screw	4	Flat hex.M8*305	SUS-304
73d	73432100161	Screw	2	Socket hex. M10*16	SUS-304
73e	73303040121	Screw	2	Round cross M4*12	SC
73f	73431050121	Screw	3	Flat hex.M5*12	SUS-304
73g	73431080301	Screw	8	Flat hex.M8*30	SUS-304
73h	73431080351	Screw	4	Flat hex.M8*35	SUS-304
74	7424316	Nut	1	M16	SUS-304
75	753430010-01	Spring washer	5	M10	SUS-304
75a	753430006-01	Spring washer	4	M6	SUS-304
75b	753430008-01	Spring washer	20	M8	SUS-304
75c	752300004-01	Washer	2	M4	SC
75d	751306304	Wave washer	2	6304	SC
75e	753430005-01	Spring washer	3	M5	SUS-304
75f	752430020-01	Washer	2	M20	SUS-304
75g	752430016-01	Washer	1	M16	SUS-304
75h	753430016-01	Spring washer	1	M16	SUS-304
75i	752430008-01	Washer	8	M8	SUS-304
76	7602-02	C'ing	1	STW25	
76a	7601-02	C'ing	1	RTW72	
77	771432-01	Key	1	5*5*15	SUS-304
79	79363041	Bearing	1	6304	
79a	79363061	Bearing	1	6306	
81	8108254200132-1	Cable	1	H07RN-F 2.5*4C*20M	
Remarks					
		O'ring & Gasket sets	1		